

## AQUABEAM MINI-VIKING

A tiny luminaire designed to accommodate a wide range of 50 mm reflector lamps offering an impressive diversity in operating voltage, power rating, color temperature and beam pattern.



**Applications include:**

Personal lighting for divers, headlights for small submersibles and R.O.V.s., and illumination for underwater TV and filming operations.

**General Specification:**

Luminaire machined from HE30 aluminum bar, hard anodized and finished in stoved epoxy paint over etch primer. Female screw threads fitted with stainless steel helicoils. Yoke, cast in LM25 aluminum, hard anodized and finished in stoved epoxy. Lens bezel and connector assembly barrel, machined from HE30 aluminum and hard anodized black. Clamp screws, polypropylene moulded onto 316 stainless steel.

**Depth rating:**

In excess of 2,000 f.s.w.

**Dimensions:**

Max. diameter (bezel)	79 mm (3.11 ins.)
Width (incl. yoke assembly)	125 mm (4.92 ins.)
Length (incl. connector)	134 mm (5.27 ins.)
Yoke mounting socket	12.5 mm (0.5 ins.)
Dry Weight	675 grams (1.48 lbs)
Immersed Weight	450 grams (1.00 lbs)

**Ordering Advice:**

For a Mini-Viking to house low voltage reflector lamps, i.e. 30 volts or less, order "Mini-Viking 120" to accommodate 120 volt reflector lamps.

All other components should be ordered under the relevant Part Code.

Order Code	Volt/Watt (Hours)	Life Temp. °K	Color Beam	Average Angle (immersed)
M190	12V/20W	2000	2925	50°
BAB	12V/20W	2000	925	27°
ESX	12V/20W	2000	2925	9°
M324	12V/35W	2000	2925	50°
FNV	12V/50W	3000	3050	45°
EXN	12V/50W	3000	3050	29°
EXT	12V/50W	3000	3050	10°
M98	12V/75W	2000	3050	50°
EYC	12V/75W	3500	3050	29°
EYF	12V/75W	3500	3050	11°
EXV*	12V/100W	50	3350	38°
M58	24V/50W	2000	3050	29°
EWf	24V/200W	50	3300	38°
EKP	30V/80W	25	3350	30°
ELC	24V/250W	50	3400	27°
EXS*	30V/200W	50	3300	30°
ELH	120V/300W	35	3350	19°
ENH	120V/250W	175	3250	19°
EXX*	120V/250W	25	3300	32°



## AQUABEAM MINI-VIKING

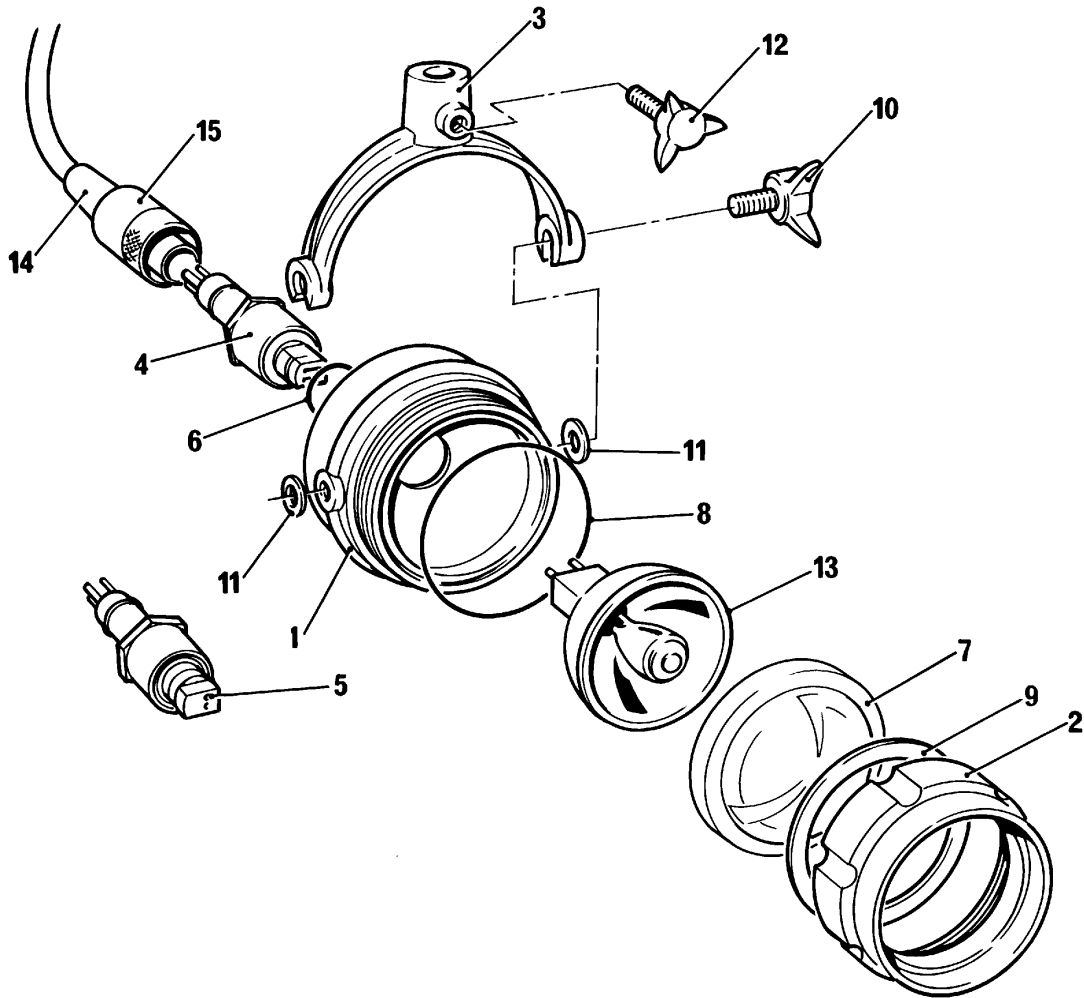

### MINI-VIKING Components

Index	Description	Part Code
1	Body	MV10
2	Bezel	MV11
3	Yoke	MV12
4	Connector Assy 120V	MV13
5	Connector Assy-LV	MV14
6	Connector Assy O'ring	MV15
7	Lens	MV16
8	Lens O'ring	MV17
9	Lens Washer	MV18
10	Body Clamp Screw (2)	MV19
11	Clamp Screw Washer (2)	MV20
12	Yoke Clamp Screw	MV21
13	Reflector Lamp	See lamp list
14	In-Line Connector (fem)	ARMG-3-FS
15	Aquabeam Lock Sleeve	MV24
-	Connector Assy Spanner	MV25

